

**BEST
BLOCK**
CONSTRUCTION MATERIALS



SIZE & SHAPE GUIDE



4 INCH CMU

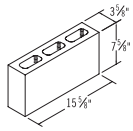

**4x8x16
Regular**

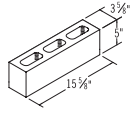

**4x5x16
Starter**

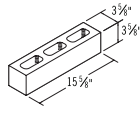

**4x4x16
Half-High**

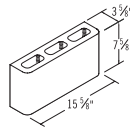

**4x8x16
DBN Plaster**

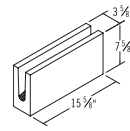

**4x8x16 Solid Bottom
Bond Beam**

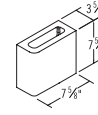

4x8x8

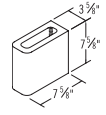

**4x8x8
DBN Half**

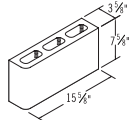

**4x8x16
SBN**

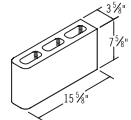

**4x8x1
DBN**

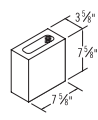

**4x8x8
Half**

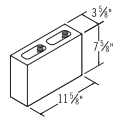

**4x8x12
Three-Quarter**

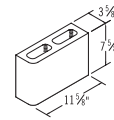

**4x8x12 SBN
Three-Quarter**

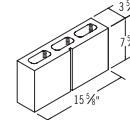

**4x8x16
Single Score**

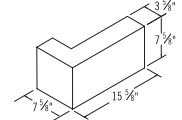

**4x8x16
L-Corner**



**4x8x4
Jumbo Brick**

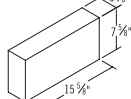

**4x8x16
Solid**

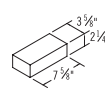

**4x2 1/4 x 8
Utility Brick**

6 INCH CMU

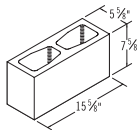

**6x8x16
Regular**

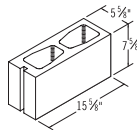

**6x8x16
Sash**

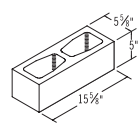

**6x5x16
Starter**

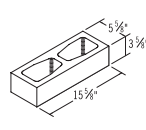

**6x4x16
Half High**

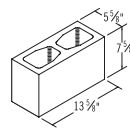

**6x8x14
Corner**

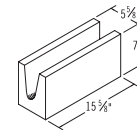

**6x8x16 Solid
Bottom Bond Beam**

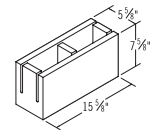

**6x8x16 Knock Out
Bond Beam**

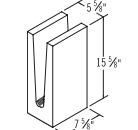

**6x16x8 Deep Lintel Bond
Beam**

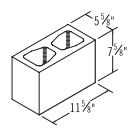

**6x8x12
Three Quarter**

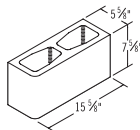

**6x8x16
SBN**

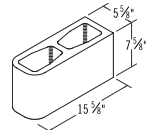

**6x8x16
DBN**

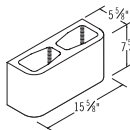

**6x8x16
DBN Plaster**

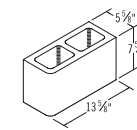

**6x8x14
SBN**

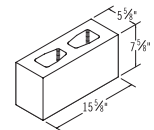

**6x8x16
2-Hour Firewall**

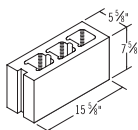

**6x8x16 Knock-Out
Deep Lintel**

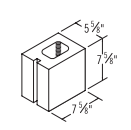

**6x8x8
Half Sash**

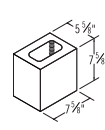

**6x8x8
Half**

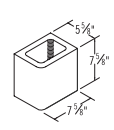

**6x8x8
SBN Half**

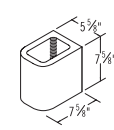

**6x8x8
DBN Half**

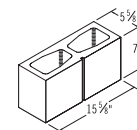

**6x8x16
1-Score**

8 INCH CMU

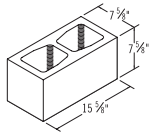

8x8x16
Regular

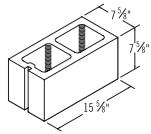

8x8x16
Sash

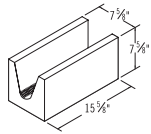

8x8x16 Solid Bottom
Bond Beam

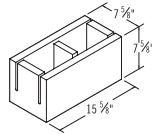

8x8x16 Knock Out
Bond Beam

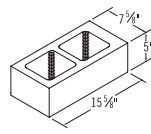

8x5x16
Starter

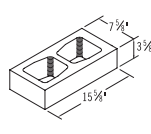

8x4x16
Half High

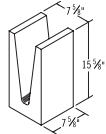

8x16x8 Deep Lintel
Bond Beam

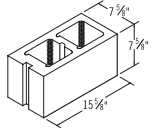

8x8x16
Conduit

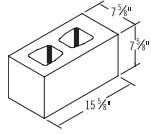

8x8x16
4-Hour Firewall

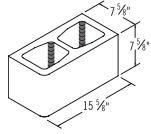

8x8x16
SBN

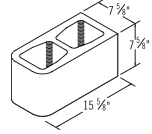

8x8x16
DBN

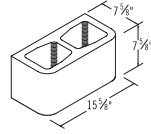

8x8x16
DBN Pillar

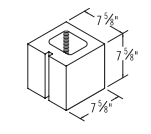

8x8x8
Half

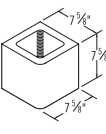

8x8x8
SBN Half

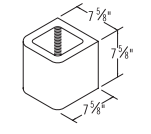

8x8x16
DBN Half

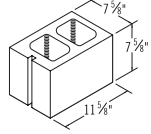

8x8x12
Three Quarter

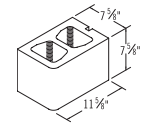

8x8x12 SBN
Three Quarter

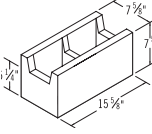

8x8x16
RS Bond Beam

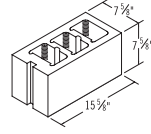

8x8x16 Knock-Out Deep
Lintel

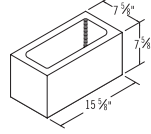

8x8x16
Single Core

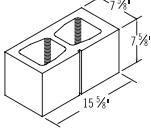

8x8x16
1-Score

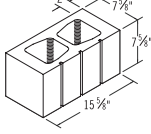

8x8x16
3-Score

10 INCH CMU

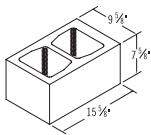

10x8x16
Regular

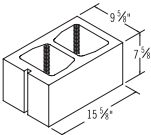

10x8x16
Sash

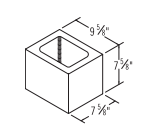

10x8x8
Half

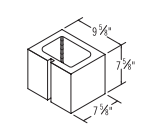

10x8x8
Sash

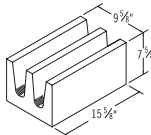

10x8x16 Solid Bottom
Bond Beam

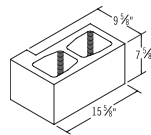

10x8x16
L Corner

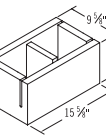

10x8x16
Knock Out Beam

12 INCH CMU

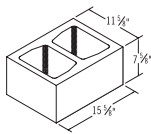

12x8x16
Regular

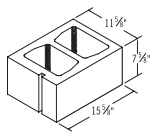

12x8x16
Sash

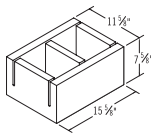

12x8x16 Knock-Out
Bond Beam

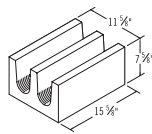

12x8x16 Solid Bottom
Bond Beam

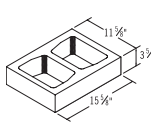

12x4x16
Half High

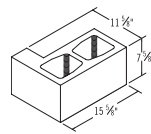

12x8x16
L Corner

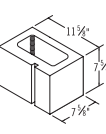

12x8x8
Half

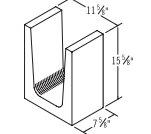

12x16x8 Deep Lintel
Bond Beam

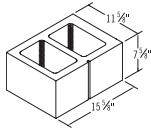

12x8x16
One Score

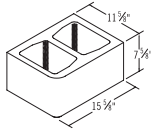

12x8x16
Single Bullnose

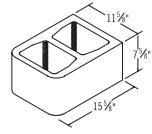

12x8x16
Double Bullnose

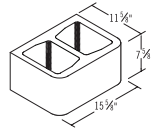

12x8x16
DBN Pillar

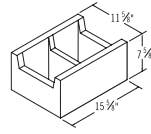

12x8x16
RS Bond Beam

Please call for Product Availability

www.bestblock.com

POLISHED CMU (AVAILABLE IN GROUND FACE, POLISHED AND TEXTURED)

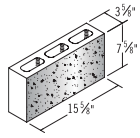

4x8x16
One Face

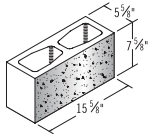

6x8x16
One Face

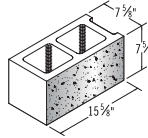

8x8x16
One Face

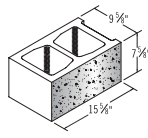

10x8x16
One Face

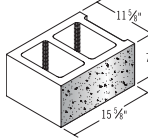

12x8x16
One Face

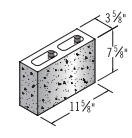

4x8x12 1F, 1E Corner

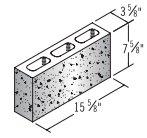

4x8x16 1F, 1E Corner*

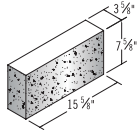

4x8x16 Solid 1F, 1E
Corner*

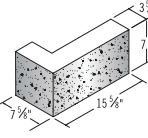

4x8x16 1F, 1E L-Corner

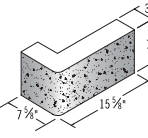

4x8x16 1F, 1E L-Corner
SBN

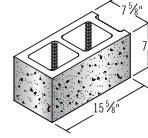

8x8x16 1F, 1E Corner*

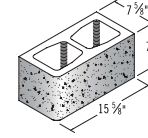

8x8x16 1F, 1E
SBN*

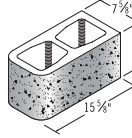

8x8x16 1F, 1E
DBN*

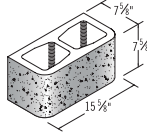

8x8x16 1F, 2E
DBN PL*

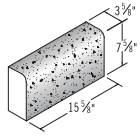

4x8x16 1F, 1T
SBN*

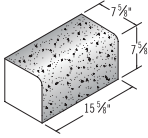

8x8x16 1F, 1T
SBN*

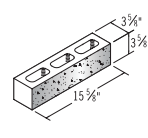

4x4x16 1F
HH*

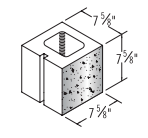

8x8x8 1F
Half*

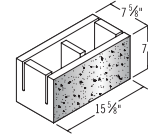

8x8x16 1F
Knock Out BB*

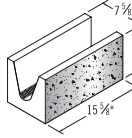

8x8x16 1F Solid Bottom
BB*

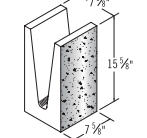

8x16x8 1F Deep Lintel BB*

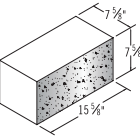

8x8x16
Solid 1F*

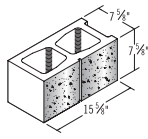

8x8x16 1F
One-Score*

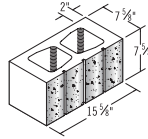

8x8x16 1F
Three-Score*

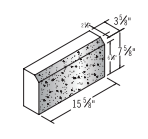

4x8x16 1F
Chamfer*

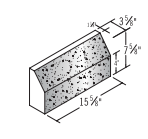

4x8x16 1F
Chamfer*

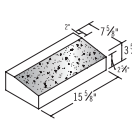

8x4x16
Chamfer*

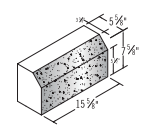

6x8x16 1F
Chamfer*

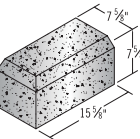

8x8x16 Solid
Pyramid Cap*

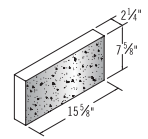

2 1/4 x 8 x 16
1F Solid

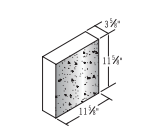

4x12x12 1F
Solid

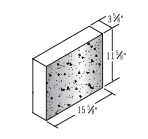

4x12x16 1F
Solid

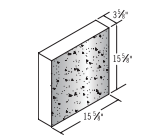

4x16x16 1F
Solid

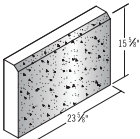

4x16x24
1F Chamfer

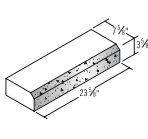

8x4x24 1F
Chamfer

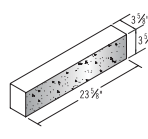

4x4x24 1F
Solid

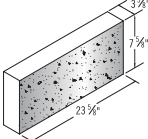

4x8x24 1F
Solid

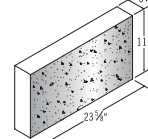

4x12x24 1F
Solid

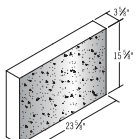

4x16x24 1F Solid

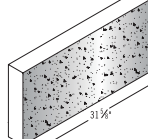

4x16x32 1F Solid



ALL UNITS ARE AVAILABLE IN THE ANGLES INDICATED. ADDITIONAL SHAPES, ANGLES AND CHAMFERS AVAILABLE UPON REQUEST.

LEGEND	
BB	Bond Beam
DBN	Double Bullnose
E	End
F	Face
HH	Half High
KOL	Knock Out Lintel
PL	Pilaster
SBN	Single Bullnose
T	Top

Chamfer Finishes: Ground Face, Polished and Textured. Please call your Best Block sales representative for specific information and availability.

*ALSO AVAILABLE IN 4", 6", 8", 10", 12" SIZE UNITS

SPECIAL CUTS (AVAILABLE IN GROUND FACE, POLISHED AND TEXTURED)

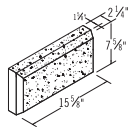

**2 1/4 x 8 x 16
GFT Chamfer**

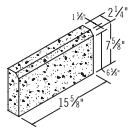

**2 1/4 x 8 x 16 GFTE
DBL Chamfer**

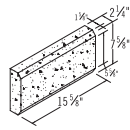

**2 1/4 x 8 x 16
GFTE Chamfer**

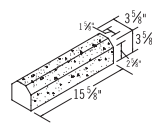

**4x4x16 GFT
DBL Chamfer**

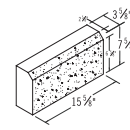

**4x8x16 GF
Chamfer**

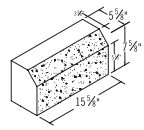

**6x8x16 GF
Chamfer**

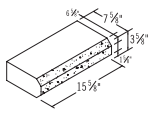

8x4x16 GF DBL Chamfer

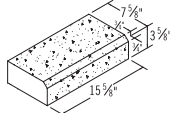

**8x4x16 GFT
Chamfer**

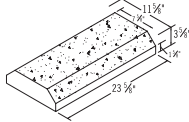

12x4x24 GT DBL Chamfer

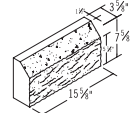

4x8x16 SF Solid Chamfer

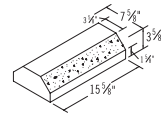

**8x4x16 DBL
Chamfer**

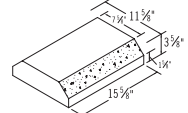

**12x4x16 DBL
Chamfer**

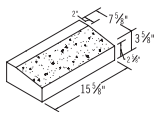

**8x4x16
Chamfer Sill**

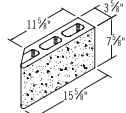

**4x8x16 GF
w/Quirk Miter**

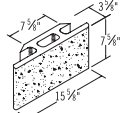

**4x8x16 GF
w/ DBL Quirk Miter**

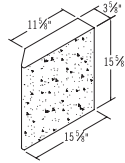

**4x16x16 GF Solid
w/Quirk Miter**

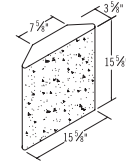

**4x16x16 GF Solid
w/ DBL Quirk Miter**

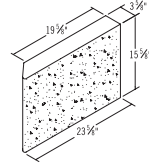

**4x16x24 GF Solid
w/ Quirk Miter**

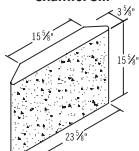

**4x16x24 GF Solid
w/ DBL Quirk Miter**

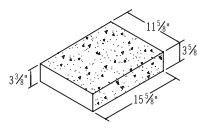

**12x4x16 GFT
Beveled Sill**

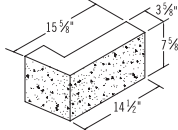

**4x8x14-1/2 GFE
w/ 106° Return**

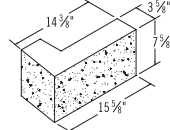

**4x8x16 GFE
w/ 74° Return**

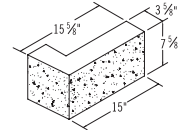

**4x8x15 GFE
w/ 97° Return**

Chamfer Finishes: Ground Face, Polished and Textured.
Please call your **Best Block** sales representative for
specific information and availability.



ALL UNITS ARE AVAILABLE IN THE ANGLES
INDICATED. ADDITIONAL SHAPES, ANGLES AND
CHAMFERS AVAILABLE UPON REQUEST.

LEGEND
DBL Double
E End
F Face
G Ground
SF Split Face
T Top

FOUNDATION

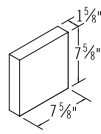

2x8x8

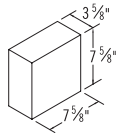

4x8x8

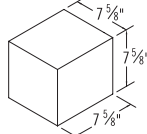

8x8x8

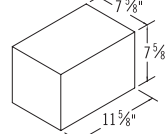

8x8x12
HP Solid

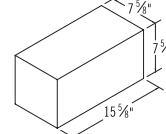

8x8x16
HP Solid

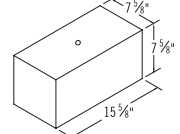

8x8x16 HP Solid
(3/4" Hole)

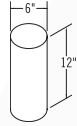

6x12
6" Solid Cylinder

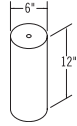

6x12 6" Cylinder
(3/4" Hole)

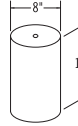

8x12 8" Cylinder
(3/4" Hole)

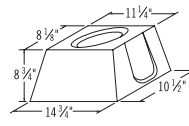

6" HP
Solid Pile Cap

SOLIDS

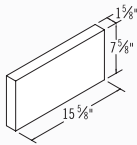

15/8x8x16

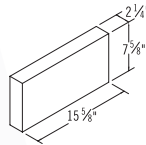

21/4x8x16

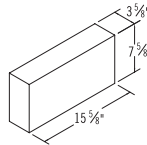

4x8x16

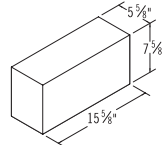

6x8x16

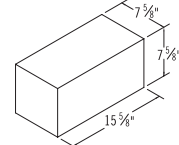

8x8x16

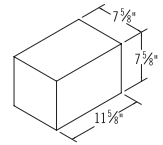

8x8x12

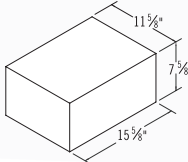

12x8x16
Solid

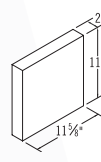

2x12x12
Patio

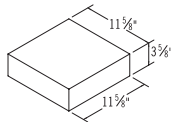

12x4x12
Solid

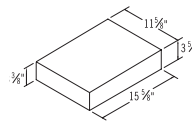

12x4x16
Solid Beveled

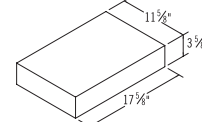

12x4x18
Base

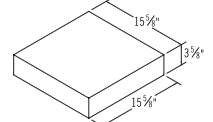

16x4x16
Solid

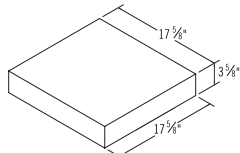

18x4x18 Base

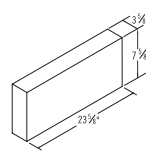

4x8x24

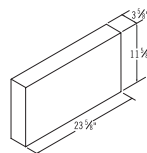

4x12x24
Solid

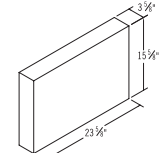

4x16x24
Solid

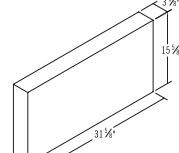

4x16x32
Solid

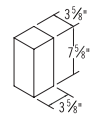

4x8x4
Jumbo Brick

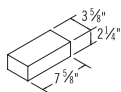

4x21/4x8
Utility Brick

SOUND ABSORBING & INSULATED

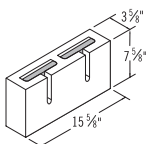

4x8x16 Acousta-Wal

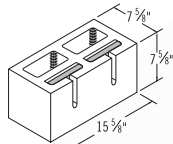

8x8x16 Acousta-Wal
Type IV RF

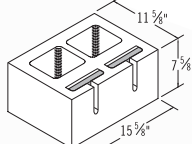

12x8x16 Acousta-Wal
Type IV RF

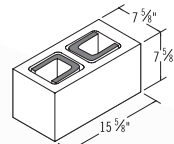

8x8x16
Korfil Insulated*

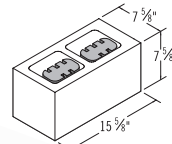

8x8x16
Icon Insulated*

LANDSCAPE / RETAINING WALL

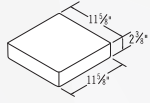

**12x2x12
Paver**



4x2-3/8x8



4x2-3/8x8

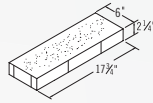

**6 x 2 1/4 x 18 Paver
Keystone Campton**

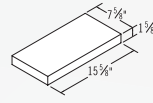

**8x1-5/8x16
Patio Heavyweight**

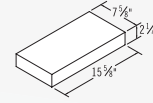

**8 x 2 1/4 x 16
Patio Heavyweight**

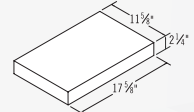

**12 x 2 1/4 x 18
Patio Heavyweight**

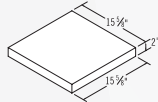

**16x2x16
Stepping Stone**

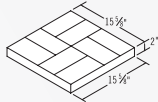

**16x2x16
Patio Stone: Brick Pattern**

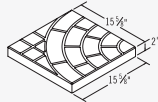

**16x2x16
Patio Stone: Fan Pattern**

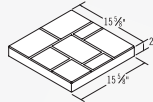

**16x2x16
Patio Stone: Ashlar**

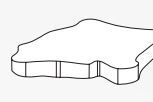

**12x18x2
Patio Stone: Canyon**

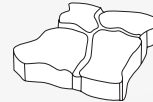

**13x11x2
Patio Stone: Alameda**

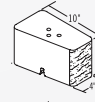

**Keystone County Manor
Small Unit**

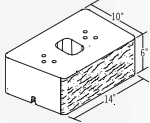

**Keystone County Manor
Large Unit**

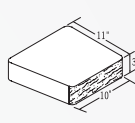

**Keystone County Manor
Cap Unit**

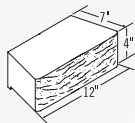

**Keystone Garden Wall
Unit: Jaw Split**

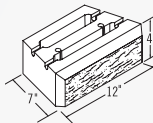

**Keystone Insignia
Wall Unit**

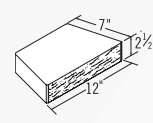

**Keystone Insignia
Cap Unit**

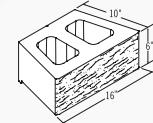

**Keystone Legacy
Hewnstone Wall Unit**

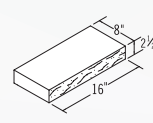

**Keystone Legacy
Hewnstone Cap Unit**

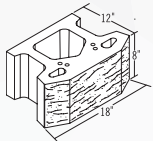

**Keystone Compac III
Tri-Plane**

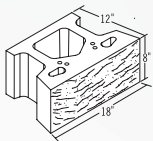

**Keystone Compac III
Straight Split**

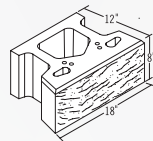

**Keystone Compac III
Victorian Split**

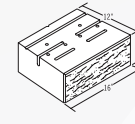

**Versa-Lok
Standard Unit**

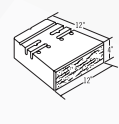

**Versa-Lok
Accent Unit**

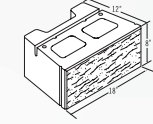

**Versa-Lok
Square Foot Unit**

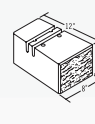

**Versa-Lok
Cobble Unit**

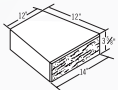

**Versa-Lok
A-Cap**

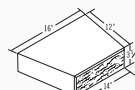

**Versa-Lok
B-Cap**

SPECIAL BLOCKS

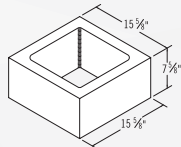

16x8x16

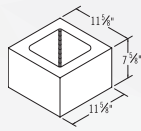

12x8x12

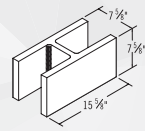

8x8x16

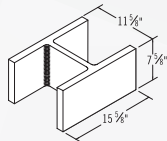

**12x8x16
H Block**

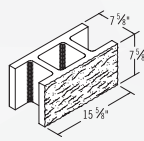

**8x8x16
Fence Block**

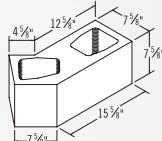

**8x8x16 135°
Corner Y Block**

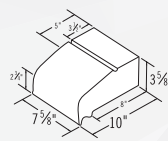

**10x4x8
Sill**

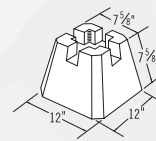

**12x8x12
Pier Block**

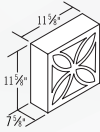

**8x12x12
Screen Block**

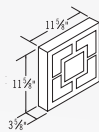

**4x12x12
Screen Block**

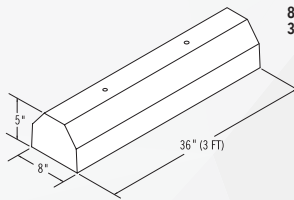

**8x5x36
3-Ft Parking Curb**

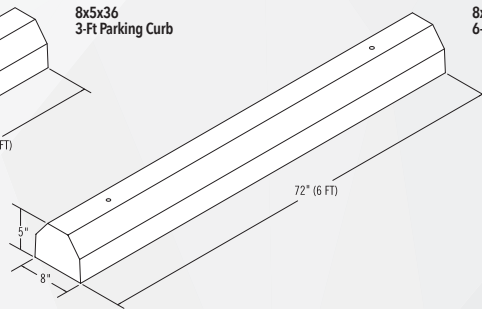

**8x5x72
6-Ft Parking Curb**

**REDEFINING
CONCRETE
MASONRY**

Best Block has extensive experience in the production of Concrete Masonry Units (CMU) and ensures all products are manufactured to meet or exceed ASTM Standards.

SOUTH TEXAS:

ALLEYTON PLANT & OFFICE
2088 FM 949 - Alleyton, TX 78935
(713) 393.3395 or (888) 464.9341

SAN ANTONIO PLANT & OFFICE
2233 Ackerman Road - San Antonio, TX 78219
(210) 666.4989 or (888) 464.2399

EAST HOUSTON PLANT & OFFICE
10538 Beaumont Hwy - Houston, TX 77078
(713) 672.7531

WESTERN BRICK OFFICE
7620 Washington Avenue - Houston, TX 77007
(713) 861.1751

AUSTIN-MPI

North Austin: 835 Kramer Lane - Austin, TX 78758
(512) 821.3303 or (800) 796.7707

South-Central Austin: 4213 Todd Lane - Austin, TX 78744
(512) 735.1000

NORTH TEXAS:

DALLAS PLANT & OFFICE
2202 Chalk Hill Road - Dallas, TX 75212
(972) 263.5077 or (888) 202.9272

PALESTINE PLANT & OFFICE
2500 West Regan - Palestine, TX 75802
(903) 729.2217 or (800) 594.7967

LOUISIANA:

SOUTHLAND BLOCK (PLANT & SALES)
4747 Choctaw Dr. - Baton Rouge, LA 70805
(225) 355.3312

www.bestblock.com

Committed to serving specifiers, contractors and installers across the country, Best Block manufactures the highest quality line of architectural and standard block as well as segmental retaining walls on the market. Offering products in a wide array of shapes, sizes, colors, textures and finishes, Best Block delivers strength, beauty and function to any residential or commercial project. A QUIKRETE Company, Best Block is a one-stop-shop for customers with advanced formula pre-blended mortars and grouts available through Spec Mix and QUIKRETE. Turn to Best Block for your next masonry project

ALLEYTON

DALLAS

PALESTINE

HOUSTON

SAN ANTONIO

AUSTIN

BATON ROUGE

