

4x8 60mm Holland Stone

Product No: 21700

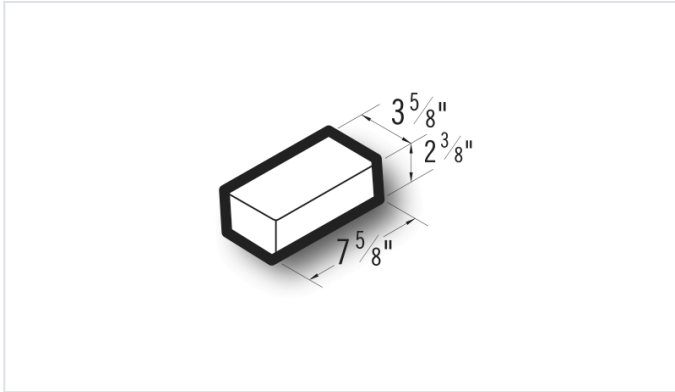

4x8 60mm Holland Stone pavers offers a wide variety of colors, patterns, sizes and textures to handle the project and enhance the natural beauty of the surroundings. [Contact](#) your Best Block representative for special requests and additional options.

- Available in medium, normal, and light-weight varieties
- Competitively priced and produced locally.
- Concrete blocks are naturally fire-resistant, highly durable, and its mass creates energy-efficient wall systems.
- Item weight and pallet count may vary by location.
- [Contact](#) your Best Block representative for more information.

Unit(s)

Product No.	21700
Weight/Block:	6
Block/Pallet:	480
Pallet Weight:	2880