

6x2 1/4x18 Campton Paver

Product No: 601892790

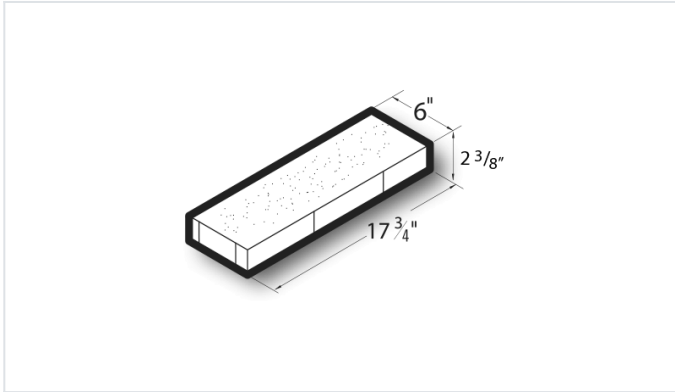

6x2 1/4x18 Campton Paver is also available in a wide variety of other colors, patterns, sizes and textures to handle the project and enhance the natural beauty of the surroundings. [Contact](#) your Best Block representative for special requests and additional options.

- Available in medium, normal, and light-weight varieties
- Competitively priced and produced locally.
- Concrete blocks are naturally fire-resistant, highly durable, and its mass creates energy-efficient wall systems.
- Item weight and pallet count may vary by location.
- [Contact](#) your Best Block representative for more information.

Unit(s)

Product No.	601892790
Weight/Block:	22
Block/Pallet:	160
Pallet Weight:	3580