

8x8x16 Solid HP Block

Product No: 80803

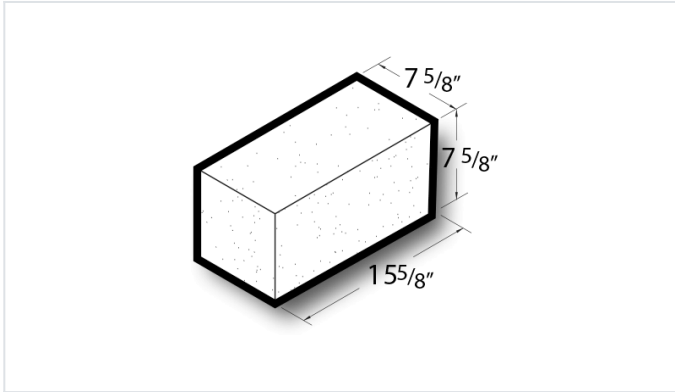

8x8x16 Solid HP Block are solid concrete masonry units intended for use as foundation piers in the construction of free-standing structures. [Contact](#) your Best Block representative for special requests and additional options.

- Available in medium, normal, and light-weight varieties
- Competitively priced and produced locally.
- Concrete blocks are naturally fire-resistant, highly durable, and its mass creates energy-efficient wall systems.
- Item weight and pallet count may vary by location.
- [Contact](#) your Best Block representative for more information.

Unit(s)

Product No.	80803
Weight/Block:	76
Block/Pallet:	60
Pallet Weight:	4620