

Insignia Wall Unit

Product No: 703068700

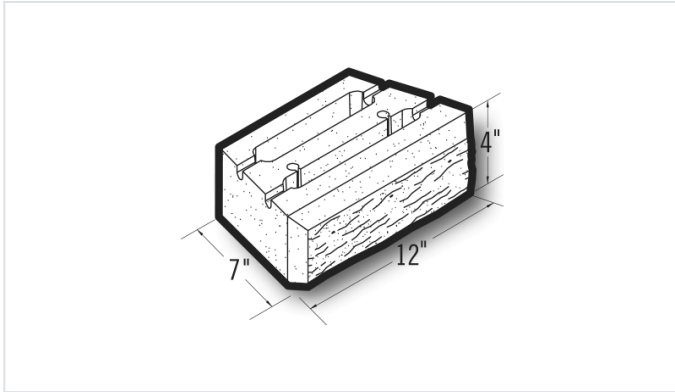

Insignia Wall Unit are designed to fulfill the needs of any landscape project, from both an aesthetic and a functional standpoint. segmental retaining wall blocks are available in a wide variety of colors, sizes, and textures to create straight or curved lines, steps, and corners. [Contact](#) your Best Block representative for special requests and additional options.

- Available in medium, normal, and light-weight varieties
- Competively priced and produced locally.
- Concrete blocks are naturally fire-resistant, highly durable, and its mass creates energy-efficient wall systems.
- Item weight and pallet count may vary by location.
- [Contact](#) your Best Block representative for more information.

Unit(s)

| | |
|-----------------------|-----------|
| Product No. | 703068700 |
| Weight/Block: | 20 |
| Block/Pallet: | 140 |
| Pallet Weight: | 2860 |