

8x8x16 Block with Korfil Inserts

Product No: 802500100

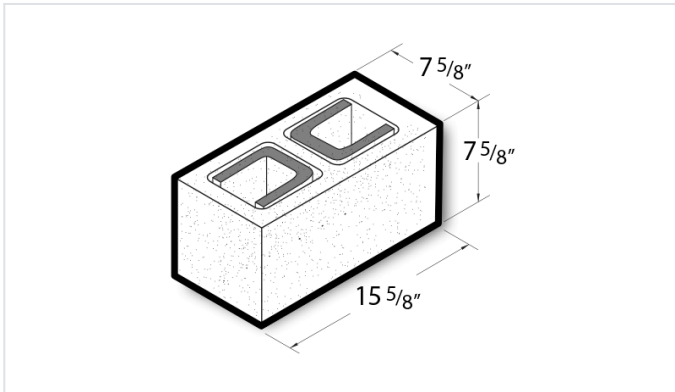

8x8x16 Block with Korfil Inserts are also available in a variety of other shapes, sizes, and inserts for what your project requires. [Contact](#) your Best Block representative for special requests and additional options.

- Available in medium, normal, and light-weight varieties
- Competitively priced and produced locally.
- Concrete blocks are naturally fire-resistant, highly durable, and its mass creates energy-efficient wall systems.
- Item weight and pallet count may vary by location.
- [Contact](#) your Best Block representative for more information.

Unit(s)

Product No.	802500100
Weight/Block:	35
Block/Pallet:	72
Pallet Weight:	2580